

Order no.	Version	PN	Dimensions/DN										
			50	65	80	100	125	150	200	250	300	350	400
3600	with non-rising spindle	10	●	●	●	●	●	●	●				
		6								●	●	●	●
3600EL	with non-rising spindle and adaptor for connecting electric actuator	10			●	●	●	●	●				
		6								●	●		●

Ask for a special leaflet.

Resilient seated gate valve for many applications in for example sewage treatment plants, the paper industry, the mining industry, the chemical and animal feed stuff industries and for low viscosity fluids and dry products.

High corrosion resistance is ensured by the use of high grade stainless steel for the knife and spindle and epoxy powder coating for the grey cast iron body.

The Knife Gate Valve can be mounted either between two flanges in a pipeline or with an opposing flange at the end of a pipeline.

The bore is clear and unobstructed.

The valve can be operated with a handwheel, a key, an extension spindle or by an electrically powered actuator. Please specify as required.

Material and design features:

- 1 **Body** of grey iron EN-GJL -250 according to EN 1561 (GG 250-DIN 1691) epoxy powder coated inside and outside (undivided up to DN 200)
- 2 **Thrust block** DN 50 - 200 of ductile iron EN-GJS-400-18 according to EN 1563 (GGG 400-DIN 1693) DN 250 - 400 of grey iron EN-GJL -250 according to EN 1561 (GG 250-DIN 1691) epoxy powder coated
- 3 **Stainless steel spindle** 1.4301, with rolled thread, long heavy duty spindle for high resistance to wear and tear
- 4 **Knife** stainless steel 1.4301, other materials on request
- 5 **Back rest** up to DN 200, of grey iron EN-GJL -250 according to EN 1561 (GG 250-DIN 1691) inside and outside epoxy powder coated
- 6 **Spindle nut** Rg 7
- 7 **Tie bar** stainless steel 1.4301
- 8 **Hexagon bolts** A 2
- 9 **Hexagon nut** A 2
- Cross sealing and U-sealing** of elastomer
- Friction washer** of POM
- Handwheel** of grey iron EN-GJL -250 according to EN 1561 (GG 250-DIN 1691) epoxy powder coated

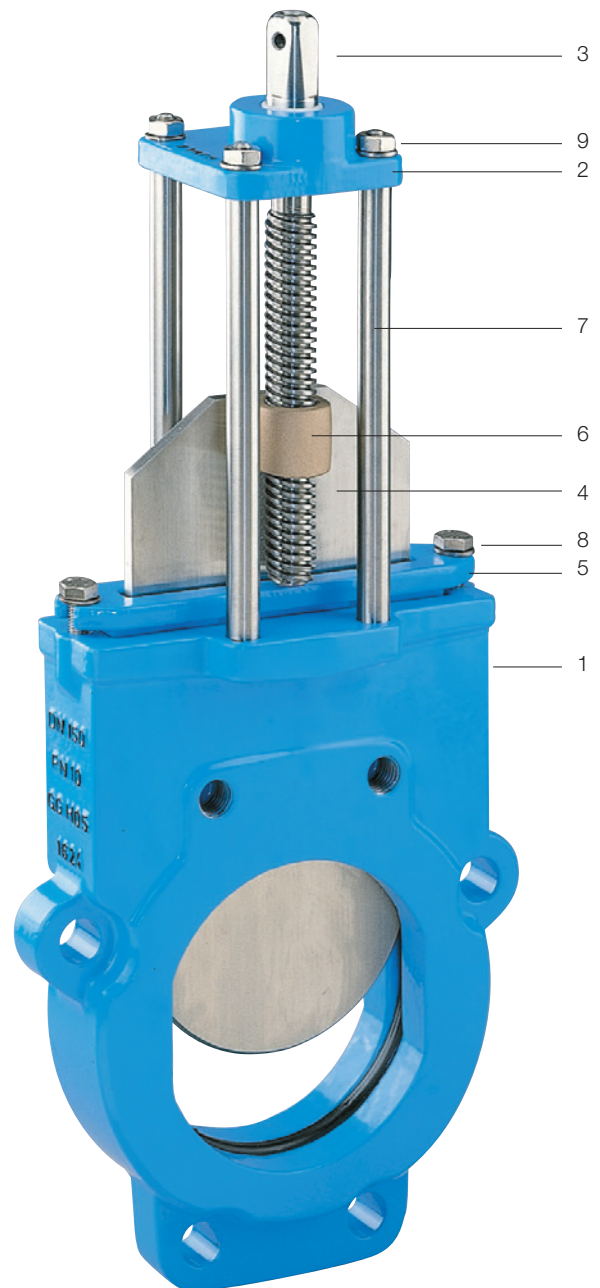

illustration DN 50 - 200

Flanges according to EN 1092-2, PN 10

Knife Gate Valve

suitable handwheels:

No. 7840
DN 80, 100, 200, 250, 300, 400

No. 7800
DN 50*/65*, 125/150, 350

* = No. 7800 DN 2"

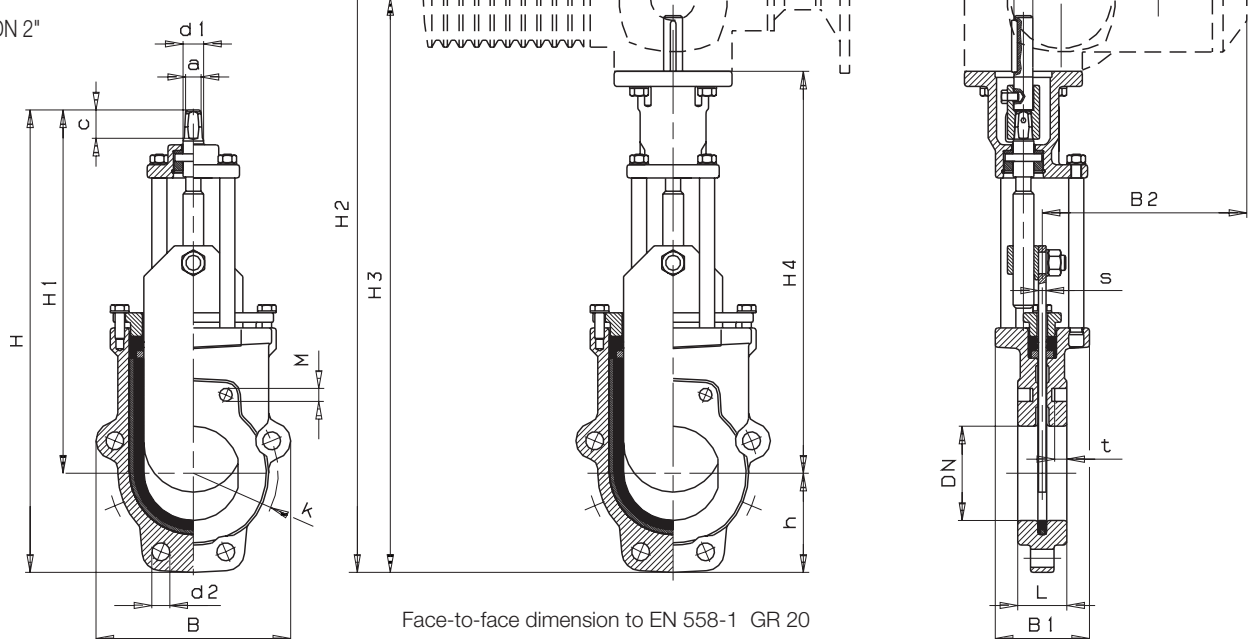

Face-to-face dimension to EN 558-1 GR 20

Dimensions	DN	50	65	80	100	125	150	200	250	300	350	400
Working pressure	PN	10	10	10	10	10	10	10	6	6	6	6
Flange	k	125	145	160	180	210	240	295	350	400	460	515
	d2	19	19	19	19	19	23	23	23	23	23	28
Bolts	Thread	M 16	M 16	M 16	M 16	M 16	M 20	M 20	M 20	M 20	M 20	M 24
	Qty.	2	2	6	6	6	6	6	8	8	10	10
- Through bore holes	Qty	4	4	4	4	4	4	4	8	8	12	12
	Qty	4	4	4	4	4	4	4	8	8	12	12
- Blind tapped holes	Qty	4	4	4	4	4	4	4	8	8	12	12
	t Depth	9,5	11	10	13	14	14	14	14	19	19	26
Bolt length with washer	Through bore holes	110	110	110	120	120	130	130	150	160	160	200
	Blind tapped holes	34	35	35	36	38	38	38	40	48	48	56
Valve	H	349	381	450	490	559	619	753	957	1081	1242	1353
	h	65	72	95	105	120	136	162	169	193	226	250
	H 1	284	309	355	385	439	483	591	788	888	1016	1103
	B	125	139	188	206	234	268	319	347	399	462	512
	L	43	46	46	52	56	56	60	68	78	78	102
	B 1	88	88	100	100	100	100	127	160	160	180	180
Spindle	a	10,3	10,3	14,8	14,8	19,3	19,3	19,3	24,3	24,3	27,3	27,3
	c	20	20	30	30	38	38	38	48	48	48	48
	d 1	16	16	22	22	25	25	28	32	32	36	36
Knife	s	6	6	8	8	8	8	10	12	12	15	15
Electric actuator	Type			SA07.5	SA07.5	SA07.5	SA07.5	SA10.1	SA10.1	SA10.1	SA14.1	SA14.1
	H 2			739	779	852	912	1048	1256	1380	1584	1695
	H 3			569	609	682	742	878	1086	1210	1404	1514
	H 4			396	426	484	528	636	837	937	1068	1155
	B 2			273	273	273	273	287	279	279	318	318
	B 3			265	265	265	265	282	282	282	385	385
	B 4			250	250	250	250	256	256	256	325	325
	Open/close revolutions			8	10	13	15	20	21	25	29	34
	d 3			20	20	20	20	20	20	20	30	30
	Weight kg	No. 3600	6,3	7,0	11,0	14,0	17,0	22,0	33,0	73,0	99,0	140,0
No. 3600EL				13,0	16,0	19,5	24,5	36,0	76,0	102,0	144,0	184,0